



## Continuous level transmitter for H temperature, series 450/451/452 ⊕ 453

### INSTRUCTION MANUAL - English

Thank you for purchasing 450/451/452 + 453 series level transmitter.

Before using the device, please read carefully this manual, and keep it in a safe place, for future use.

#### 1 - Description

**450/451/452** series are capacitive continuous level transmitters for solid and liquid materials. The material to be controlled can be good electric conductor, or insulating, like water, oil, diesel fuel, powders in general. They cannot be used with inflammable liquids, but they can be used with diesel fuel at  $T < 55^{\circ}\text{C}$ .

Rugged and compact, the **450/451/452** series give an output current signal, proportional to the product level, with 2/3 wires connection.

#### 2 - Technical characteristics

- dimensions are in mm:

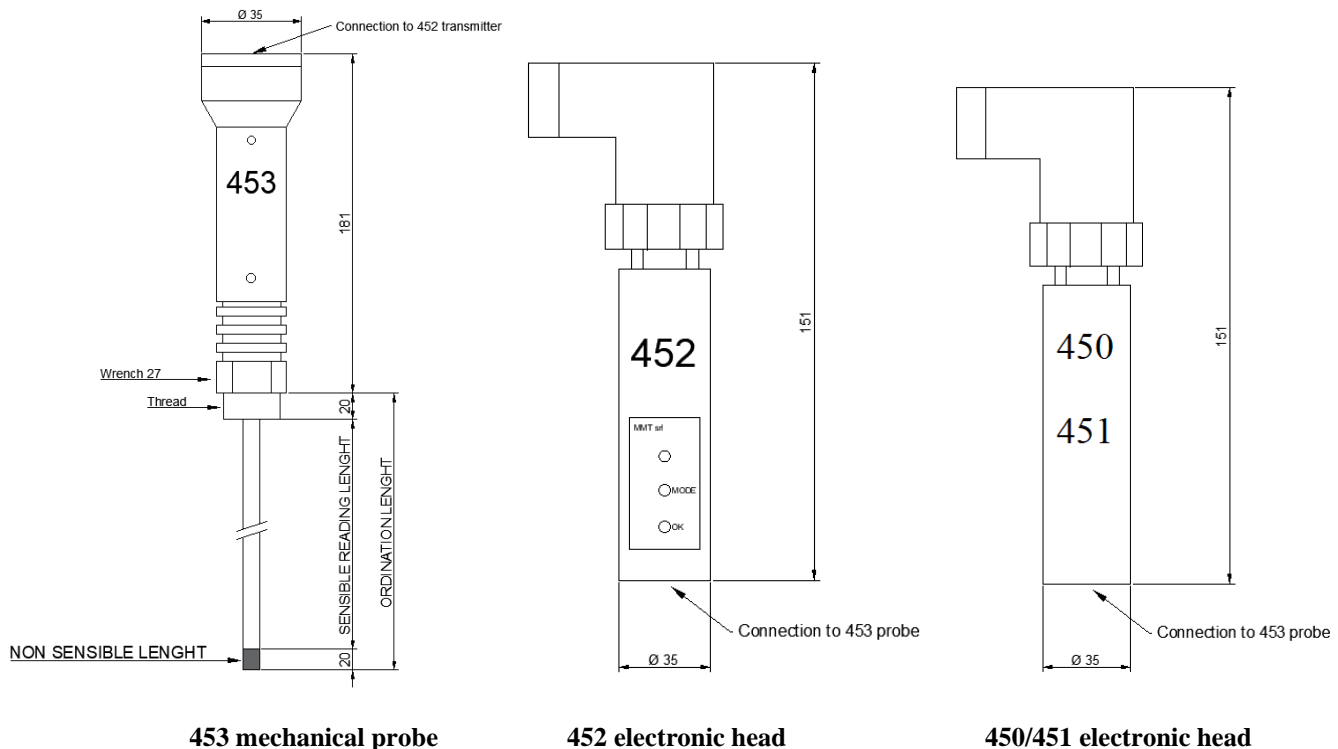

**453 mechanical probe**

**452 electronic head**

**450/451 electronic head**

Drawing #1

#### 450-451-452

- Power supply: 24Vdc  $\pm 10\%$
- protected against power supply reversal
- Output Signal: 4÷20 [mA]
- R max: 500 ohm
- absorption: 0.9 VA
- electric wiring: DIN 43650A
- precision: 0,5% f.s. after calibration, at 25°C
- 451/452: three wires; 450: two wires
- 450 (two wires): calibration not possible in field
- 451 (three wires); calibration not possible in field
- 452 (three wires); calibration possible in field

#### 453

- thread: 1/2" gas
- covering 3mm thick PTFE food compliant
- stainless steel body
- weight: 1000 g [ per L = 500 mm]
- pressure  $\leq 32$  bar
- temperature: 239 °C on the electrode
- plug: 20mm not-sensitive end, at the bottom



### 3 - Matching order codes

Depending on the length, refer to the following table for the correct matching between the 453 series probe and the 450/451/452 series electronic heads.

| length       | 453(probe) | 452(head)  | 451(head)  | 450(head)  |
|--------------|------------|------------|------------|------------|
| 350÷500 mm   | 453-505-00 | 452-010-04 | 451-005-04 | 450-00-04  |
| 501÷1000 mm  | 453-510-00 |            | 451-010-04 | 450-010-04 |
| 1001÷1500 mm | 453-515-00 | 452-015-04 | 451-015-04 | 450-015-04 |
| 1501÷1900 mm | 453-520-00 | 452-020-04 | 451-020-04 | 450-020-04 |

**Warning:** incorrect pairing between the probe and the electronic head can lead to errors in level measurement, reduction of precision; impossibility of calibration.

### 4 - Working

Once the transmitter has been installed, it generates a normalized 4÷20 mA d.c. signal proportional to the material level in the tank, with 4mA probe covered for 1.5% of the length and 20mA with probe covered for 99% of the length.

### 5 - Installation and use

#### 5.1 - Mechanical assembly

- The transmitter must be installed according to the following drawing:

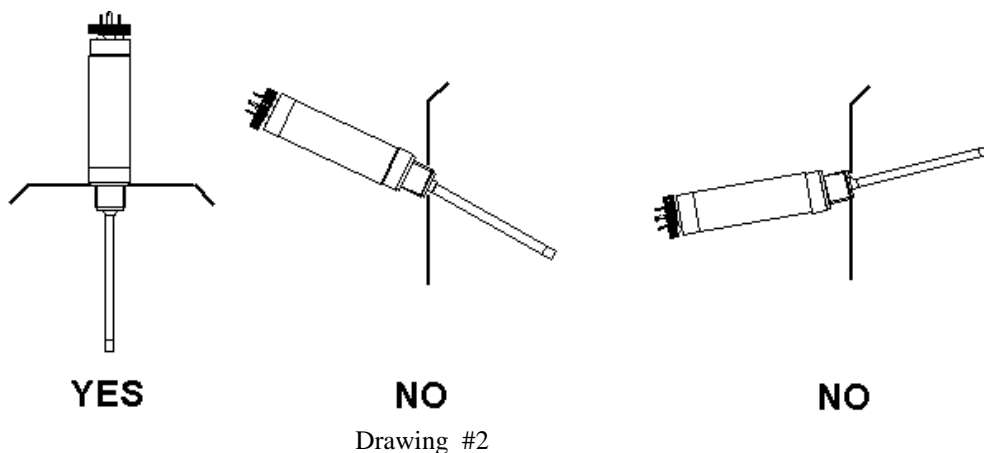

Consider the thermal stretch of the PTFE coating could be 20 ÷ 30mm.

For the use of the output signal with a regulator or PLC consider current values (mA) read during normal use condition.

The transmitter must be mounted in the tank, in vertical position, so that the tank sides aren't in contact with the probe.

The minimum measurement level (4mA) is about 1,5% of the probe height.

The maximum measurement level (20mA) is about 99% of the probe height.

The following drawing is an example for 1m long probe.

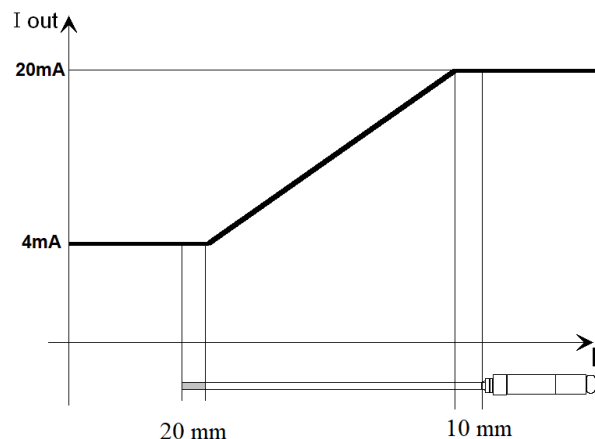



Man\_E\_450\_451\_452\_453 Rev. 4 del 28.08.2024

## 5.2 - Electric wiring

### Warning!

Avoid installing the probe before the end of the pipe welding work on the system.

The electric/electrostatic discharges produced could generate dangerous currents along the masses and therefore cause irreversible damage to the electronic part of the probe, even if it had not yet been connected/powerd.

- **Before powering the device, be sure that the power supply voltage is in the range 24 Vdc  $\pm 10\%$  .**
  - Wire the transmitter to the power supply and to the current loop receiver, according the following drawing. It is recommended the use of a shielded cable, especially for long distances.
- The maximum current loop load is 500 $\Omega$ .

### Conductive or insulating liquids in metal tank

Do not interpose flange or electric insulating gaskets (like PTFE) between the thread  $\frac{1}{2}$ " of the probe and the surface/body of the tank; the ground of the tank must be in contact with the thread  $\frac{1}{2}$ " of the probe. Anyway, connect electrically the terminal GND of the transmitter with the tank ground.

### Conductive liquids in insulating tank

You must insert inside the same tank a metallic electrode (good electric conductor) that has to be always in contact with the material to be measured, also to the least desired level; this electrode must have the same length of the probe and diameter 4mm, and must be electrically connected to the terminal GND of the transmitter.

### Insulating liquids in non metal tank

If the product to be measured is an insulating liquid and the tank is also insulating, it is necessary to place a metal tube coaxial to the antenna of the 453 probe, along its entire length. Electrically connect this tube to the GND terminal of the transmitter.

## 5.3 - Wiring diagram (three wires) for 451/452 with user not galvanically isolated

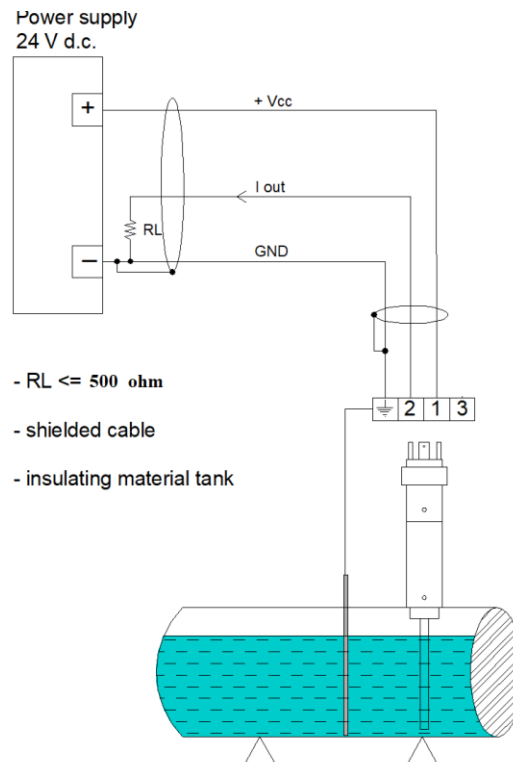
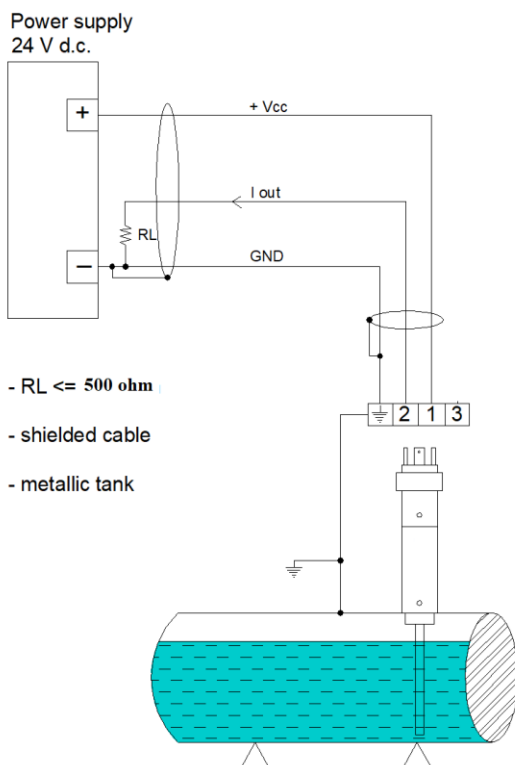



Man\_E\_450\_451\_452\_453 Rev. 4 del 28.08.2024

**5.4 - Wiring diagram (three wires) for 451/452 with user galvanically isolated**

Power supply  
24 V d.c.

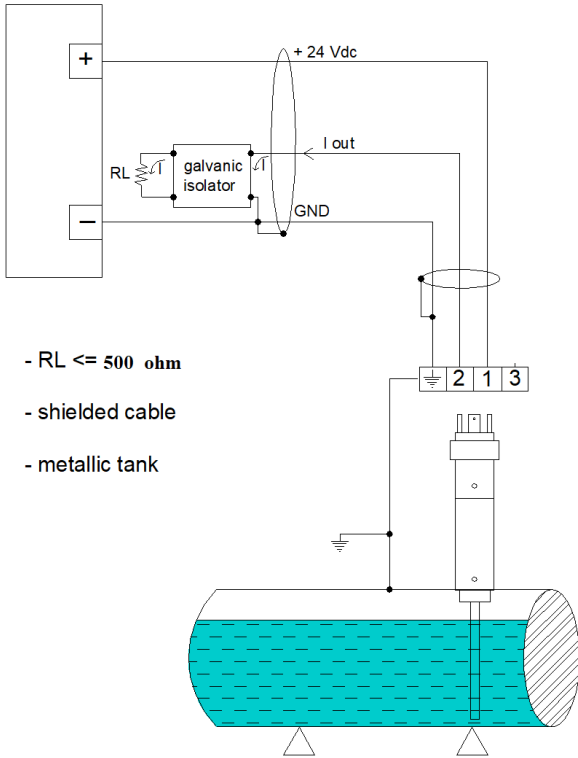

- $RL \leq 500 \text{ ohm}$
- shielded cable
- metallic tank

Power supply  
24 V d.c.

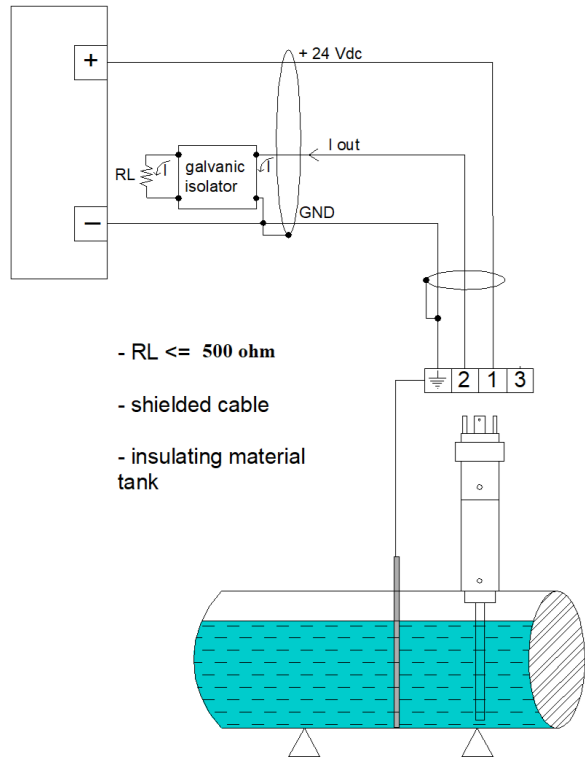

- $RL \leq 500 \text{ ohm}$
- shielded cable
- insulating material tank

**5.5 - Wiring diagram (two wires) for 450 with user not galvanically isolated**

Power supply  
24Vdc

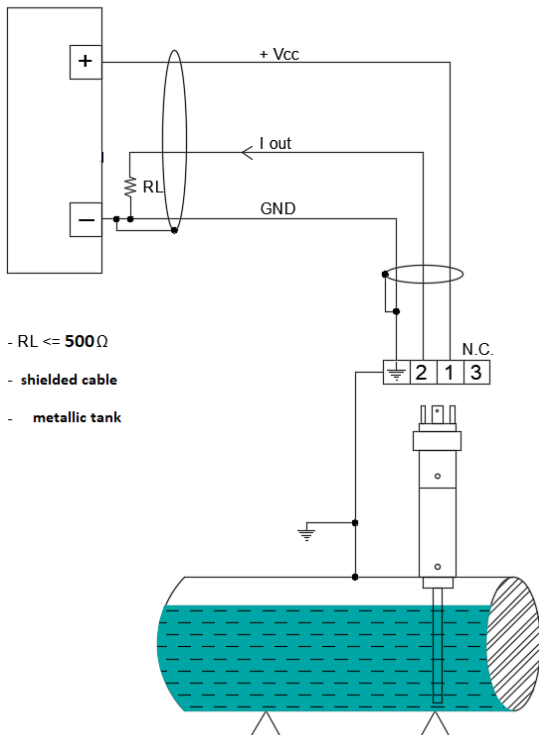

- $RL \leq 500 \Omega$
- shielded cable
- metallic tank



## 6 - Transmitter calibration (only 452 series)

The 452 (451) transmitter is supplied factory calibrated (MMT), over its entire length.

Therefore in general no field calibration by the customer is required.

However, it is possible that slight deviations in the current values are found with respect to the 4mA (empty) and 20mA (full) values, when the transmitter is placed inside small diameter pipes.

In these cases, an on-site recalibration can be performed, if required.

The calibration must be carried out along the entire length, that is, the empty must be acquired when the electrode is completely out of the liquid; while the full must be acquired when the electrode is completely immersed in the liquid.

Proceed as follows.



### 6.1 - Introduction

When the transmitter is switched on, at the end of its start-up phase, the LED flashes yellow for a few moments and then goes off. This is completely normal.

It is possible to acquire first the empty and then the full; or vice versa.

Each time the MODE button is pressed, the LED changes color according to the sequence: green - blue - yellow - off.

Pressing the MODE button or the OK button is intended for a short period of approximately 0.5".

Following the power-on, or after no button is pressed for one minute, the transmitter goes into a stand-by situation.

In this state, involuntary presses of the MODE or OK buttons are not considered.

To exit the stand-by state it is necessary to press the MODE and OK buttons simultaneously.

In the rest of the manual it will be assumed that the regulator is not in a stand-by condition.

In stand-by conditions the probe continues to deliver the 4 ... 20mA current regularly.

If the standby condition is reached after the acquisition of a level (empty or full), this level is kept in the memory and it is not necessary to repeat the acquisition, if the probe has been kept powered all the time.

Only at the end of the calibration is it possible to disconnect and restore power without losing the acquisitions made.



### 6.2 - Acquisition of empty level

Press the MODE button several times until the LED turns green .

Press the OK button.

The green LED will flash for a few moments, indicating that the probe is acquiring empty.

At the end of the flashing sequence:

- the LED will turn green again in a stable way, to indicate that the empty has been acquired correctly .
- the LED will turn red in a stable way , to indicate that there was an error in the acquisition of the empty, for example the level was not kept sufficiently stable during the acquisition.

In this case, after making sure that the level is stable, it is sufficient to repeat the operations described above to obtain a valid acquisition of the empty.

### 6.3 - Acquisition of full level

Press the MODE button several times until the LED turns blue .

Press the OK button.

The blue led will flash for a few moments, indicating that the probe is acquiring full.

At the end of the flashing sequence:

- the LED will return to being steadily lit in blue , to indicate that full has been acquired correctly



- the LED will turn red in a stable way , to indicate that there was an error in the acquisition of full, for example the level was not kept sufficiently stable during the acquisition. In this case, after having made sure that the level is stable, it is sufficient to repeat the operations described above to obtain a valid acquisition of full.



#### 6.4 - Calibration

Press the MODE button several times until the LED turns yellow .

Press the OK button.

The yellow LED will flash for a few moments, indicating that the probe is calibrating.

At the end of the flashing sequence:

- the LED will return to be steadily lit yellow , to indicate that the calibration has been carried out successfully
- the led will become red in a stable way , to indicate that it was not possible to carry out the calibration, for example because the difference in level between empty and full is less than 5% of the length of the probe. After making sure that this difference is greater than 5% (i.e. after having reacquired the empty and / or full), repeat the operations described above to obtain a valid calibration.

#### 6.5 - Alarms / Warnings

The red LED , after the empty, full or calibration acquisition operation, indicates that the operation was not successful. This condition, if no key is pressed, remains for at most 60"; at the end of which the probe returns to stand-by.

This happens because these situations are similar to warnings, that is, they can be recovered in some way by the user (for example by simply repeating the acquisition operations).

If, on the other hand, a serious non-recoverable probe failure occurs, for example water infiltration in the antenna or antenna shorted to the ground, this fact would be signaled again by the lighting of the red LED, this time permanent, to indicate that probe must be returned to MMT for repair.

In this case, in addition to the red LED, the probe signals the fault by supplying a fixed current of 3mA.

#### 7 - Notes for coupling 451 ⊕ 453 and 450 ⊕ 453

The 450 and 451 electronic heads, unlike the 452 electronic head, cannot be calibrated in the field.

They are supplied factory pre-calibrated (MMT) based on the length of the 453 probe to which they will be coupled.

If they were to be supplied as a spare, it is therefore necessary to know the length of the installed 453 probe to which they will be coupled. If the exact length of the 453 is not known, it is necessary to know among the 4 possible ranges (50cm; 100cm; 150cm; 190cm) the one that certainly exceeds the length of the 453 installed; in this case the 450/451 supplied as a spare will not be able to have the dynamics exactly corresponding to the length of the 453 and will lose some resolution; however, the PLC usually connected to the current output of the 450/451 will be able to normalize the signals, bringing them back into the desired range.

#### 8 - Notes and troubleshooting

- Don't touch the sensitive part of the probe with hands or other objects.
- It is recommended the use of a shielded cable, especially for long distances; the link cable must have a section which depends on the length: for cables up to 100 m long, 0.5 mmq; up to 500 m long , 1 mmq; up to 1 km long, 1.5 mmq [the resistance of every cable must always be lower than 15 Ω].
- The electric connection is for 4 ÷ 20 mA output signal, three wires with 451/452, and two sires with 450.
- Provide for periodic cleaning (usually every six months) to prevent any deposits on the Teflon coating sensor part, because this situation can cause anomalous reading of the transmitter, not corresponding to the true level of material.
- In the case of breaking of a current loop wire, the output current will be 0 mA, allowing easy service.
- In case of breaking of the covering in PTFE, the current can reach the maximum value overcoming 20mA, allowing one elementary diagnostic of the transmitter. The electronic part doesn't broken, but the covering in PTFE must be replaced.
- The probe must not be immersed in liquids with turbulence: this situation can cause anomalous reading of the transmitter, not corresponding to the true level of material.
- In the case of conductive liquids, like water, the probe must do not be coated with the material in its not immersed height, for example water drop or spray: this situation can cause anomalous reading of the transmitter, not corresponding to the true level of material.
- In case of irregular working, check the power supply and ground wiring; if is ok, disconnect the output of the transmitter from the user load and temporarily connect through a 100 Ω – 1/4W resistor to ground: verify that the voltage reading in parallel to that resistor changes from 0.4V to 2.0V, according to the level of the material covering the probe. Using a good digital dc mA meter it is possible to measure directly the output current, 4÷20 mA.