

# 999

## ELECTRODES AND SPACERS FOR MULTIPLE ELECTRODE HOLDERS FOR FOOD INDUSTRY

### MECHANICAL DIMENSION

### DESCRIPTION

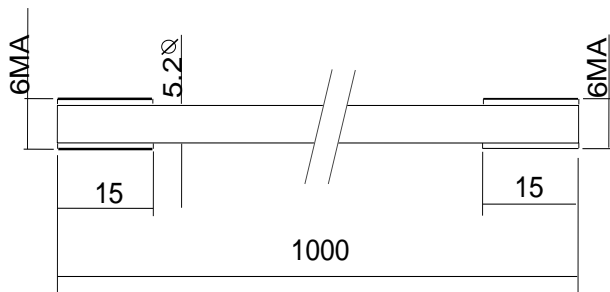

This electrode has the purpose to extend the conductive end of the electrode holder, obtaining different levels for common, minimum and maximum. It is possible to join several modules, 1 meter long.

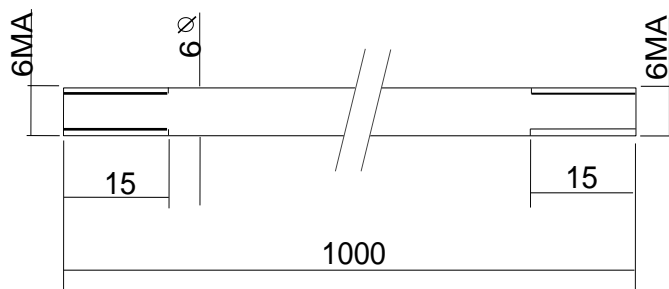

This electrode has the purpose to extend the conductive end of the electrode holder, obtaining different levels for common, minimum and maximum. It is possible to join several modules, 1 meter long.

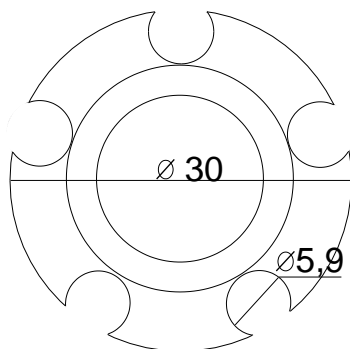

This spacer has the purpose to keep spaced the 6 mm diameter electrodes, when their length may cause a contact between them or with the tank.

### ORDER CODES

CODE	DESCRIPTION	MATERIAL
999-003-00	Electrode D5 mm, 2 thread 6MA	Stainless steel
999-005-00	Electrode D6 mm thread 6MA	Stainless steel AISI 316
999-006-00	Electrode D6 mm thread 6MA	Titanium
999-053-00	D6 mm electrode spacer	PTFE-glass doped